



Performance & ease of use

- Best lifting speed of 48 sec.
- Industry leading working envelope with an outreach of 12.2 m
- Fully proportional and simultaneous movements
- Ease of transport

Excellent robustness

- Rugged hoods with ergonomic handle
- Long lasting structural design

Easy maintenance

- Exclusive modular basket with upper control box cover and tool tray
- Easy access to all components
- Self-diagnosis tool on lower control box

Best comfort and safety feeling

- Activ'Shield™ Bar (for Europe + Latin America only)

WORKING AT HEIGHT



AH20 JRT PRO



ROUGH TERRAIN ARTICULATING BOOMS

TECHNICAL DATA

AH20 JRT PRO

Working height	20.6 m
Platform height	18.6 m
Horizontal outreach	12.2 m
Up and over clearance	8.4 m
Lift capacity	230 kg
F x G Platform size	1.83 x 0.80 m
A Length - stowed	8.8 m
B Width	2.42 m
Height - stowed	2.51 m
H Transport length	6.5 m
C Transport height	2.93 m
Vertical jib rotation	140° (+60°/-80°)
Platform rotation	180° (+90°/-90°)
Turntable rotation	360° continuous
Tailswing	14.2 cm
D Wheelbase	2.45 m
E Ground clearance	42 cm
Tilt	5°
Drive speed	0,5 - 5 km/h
Gradeability	45 %
Tires - solid rough terrain	385/65-22,5
Turning radius - outside	3,75 m
Power source	Kubota 36.5 kW - 49.5 hp
Weight	9 600 kg

STANDARD EQUIPMENT

- 4 wheel drive, 4 wheel steer
- Front oscillating axle increases stability on uneven ground
- Safe to use in winds up to 60 km/h - 37mph
- 4 simultaneous movements for maximum productivity
- 230 kg / 500 lbs (2 persons) load capacity unrestricted working envelop
- Permanent limited slip differential
- Rotating beacon
- Modular standard basket 1.83 m x 0.80 m, Drop bar entry gate
- Upper control box protection cover and tool tray in plastic ultra-solid
- AC power to platform 110 / 230 V
- Self-diagnosis tool on lower control box
- Swing out engine tray for ease of maintenance
- Hour meter
- Low fuel level indicator (upper & lower control boxes)
- Sound and light alarm for tilt and load
- 12 V battery
- Electric pump system and emergency descent
- Travel alarm
- Activ'Shield™ Bar (for Europe and Latin America only)

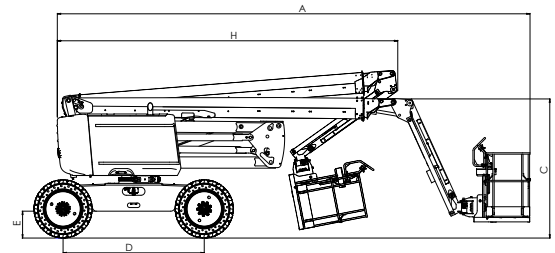
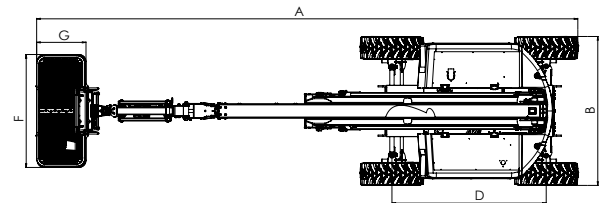
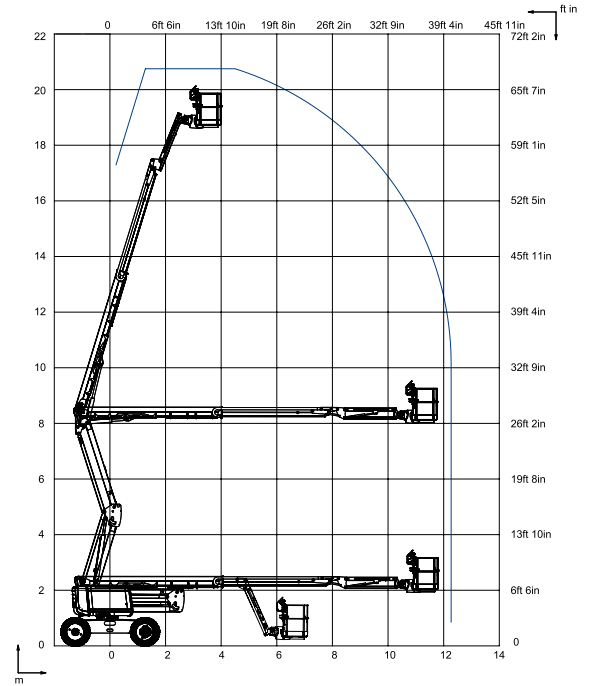

OPTIONS AND ACCESSORIES

- Large modular basket 2.44 m x 0.91 m
- Lateral swing door entry gate
- Hydraulic generator Dynaset 3.5 Kw or 12 Kw
- Air-line to platform 6.5 mm inner diameter
- 55 W working light
- Power to platform 110 / 230 V (with or without circuit-breaker 30mA)
- Flashing light
- Cold weather kit : -10°C /-25°C
- Hot weather kit : hydraulic oil cooler + hydraulic oil
- Biodegradable hydraulic oil
- Non-marking tires
- Spark arrestor and electric one-way valve
- Welder + Welder support
- Activ'Shield™ Bar (outside Europe and Latin America)

