

ROUGH TERRAIN SCISSOR LIFTS

AHS 12 SX

AHS 15 SX

AHS 18 SX

Exceptional rough terrain capability

- Hydraulic differential lock for improved RT capability
- 35 cm of ground clearance ensures exceptional rough terrain performance
- 4 wheel drive

Excellent manoeuvrability

- Tight turning radius
- Proportional controls for extremely smooth movements



WORKING AT HEIGHT

TECHNICAL DATA

	AHS 12 SX	AHS 15 SX	AHS 18 SX
Working height	12 m	15 m	18 m
Platform height	10 m	13 m	16 m
Drive speed	1.6 - 6 km/h	1.6 - 6 km/h	1.6 - 6 km/h
Driveable at full height up to	10 m	10 m	10 m
Lift capacity	700 kg	500 kg	500 kg
H Length	4.18 m	4.12 m	4.18 m
B Width	2.25 m	2.25 m	2.25 m
C Height - stowed	2.57 m	2.77 m	2.97 m
Storage height	1.71 m	1.91 m	2.11 m
G Platform length	3.91 m	4 m	4 m
A Extended platform length	6 m	6 m	6 m
Platform extension length	1 m	1 m	1 m
F Platform width	1.89 m	1.89 m	1.89 m
D Wheelbase	2.75 m	2.75 m	2.75 m
E Ground clearance	27 cm	35 cm	35 cm
Number of extensions	2	2	2
Turning radius - outside	4.96 m	4.96 m	4.96 m
Lift / lower speed	43 s / 65 s	46 s / 57 s	60 s / 60 s
Engine	23.1 kW - 31 Hp	23.1 kW - 31 Hp	23.1 kW - 31 Hp
Gradeability	40 %	40 %	40 %
Tires - foam-filled	10-16.5	10-16.5	10-16.5
Hydraulic system capacity	100 l	100 l	100 l
Weight	5640 kg	6340 kg	7300 kg

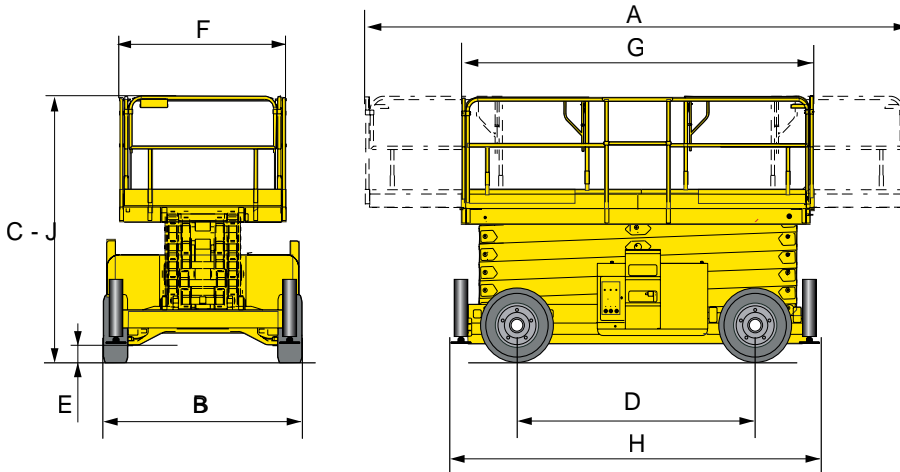

AHS 12 SX

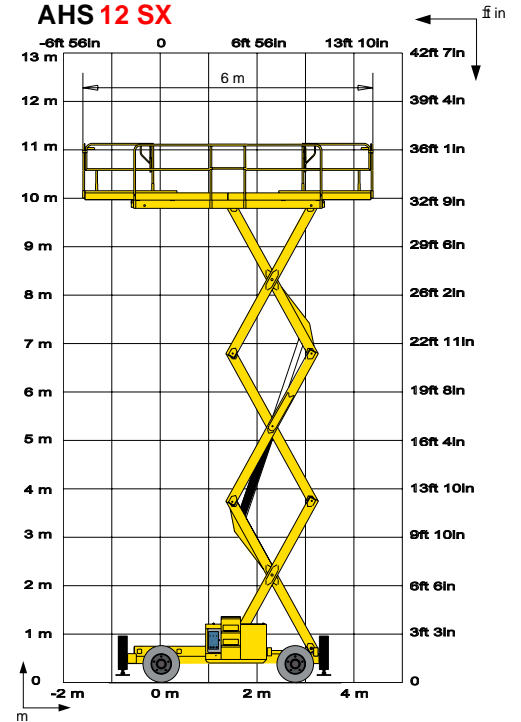

STANDARD EQUIPMENT

- 4 wheel drive (2 wheel steer)
- 5° tilt alarm
- 2 metres of platform extension
- Platform Load Management System
- 12 V - 95 Ah batteries
- 14 V - 50 A alternator
- Removable operator's control box
- Free wheeling device
- Hourmeter
- Horn
- Towing and lifting hooks
- Hydraulic brakes
- Centralised Stabiliser (18 SX)
- Manual emergency lowering system

OPTIONS AND ACCESSORIES

- Rotating beacon
- Travel alarm
- Power to platform
- Working light
- Encoded starting device
- Biodegradable hydraulic oil
- Motion alarm for movements and translation
- Non-marking tyres
- Warm Environment Kit
- Centralised outrigger control with automatic leveling (standard 18 SX)

Working At Height Limited

(Southern Office)
Amberley Court
Old Elstead Road
Milford
Surrey
GU8 5EB

Tel: 01483 415 410
Fax: 01483 417 719

Working At Height Limited

(Northern Office)
The Portergate
Ecclesall Road
Sheffield
South Yorkshire
S11 8NX

Tel: 0114 209 6206
Fax: 0114 209 6001

Suppliers of:

Powered Access Platforms
Aerial Work Platforms
Runabout Access Platforms
Scissor Lifts
Articulating Boom Access Platforms
Telescopic Boom Access Platforms
Material Lifts
Telehandlers
MEWPS Training