

# ELECTRIC SCISSOR LIFTS



## AHS 8 W AHS 10/12

### Exceptional productivity

- Load capacity up to 450 kg (AHS8W and AHS10)
- Driveable at full height
- Both inside and outside use with the same load capacity
- Extended platform
- Width of 1.20 m
- Long working cycles

### Robust, reliable, easy to maintain



**WORKING AT HEIGHT**

# ELECTRIC SCISSOR LIFTS

## TECHNICAL DATA

|  | AHS 8 W             | AHS 10              | AHS 12                |
|--|---------------------|---------------------|-----------------------|
| Working height                             | 8.27 m              | 10.15 m             | 11.98 m               |
| Platform height                            | 6.27 m              | 8.15 m              | 9.98 m                |
| Driveable at full height up to             | 6.27 m              | 8.15 m              | 9.98 m                |
| Lift capacity - inside                     | 450 kg              | 450 kg              | 300 kg                |
| Lift capacity - outside                    | 450 kg              | 450 kg              | 300 kg                |
| <b>A</b> Platform length - outside         | 2.31 m              | 2,31                | 2.31 m                |
| <b>B</b> Platform length - extended        | 3.23 m              | 3.23 m              | 3.23 m                |
| Length - extension                         | 0.92 m              | 0.92 m              | 0.92 m                |
| <b>C</b> Platform width - outside          | 1.2 m               | 1.2 m               | 1.2 m                 |
| <b>E</b> Storage height                    | 1.28 m              | 1.4 m               | 1.53 m                |
| <b>D</b> Height - stowed                   | 2.14 m              | 2.26 m              | 2.39 m                |
| <b>F</b> Overall width                     | 1.2 m               | 1.2 m               | 1.2 m                 |
| <b>G</b> Length                            | 2.49 m              | 2.49 m              | 2.49 m                |
| <b>H</b> Wheelbase                         | 1.86 m              | 1.86 m              | 1.86 m                |
| <b>I</b> Ground clearance - Center         | 13 cm               | 13 cm               | 13 cm                 |
| Ground clearance - Pothole guards deployed | 2.5 cm              | 2.5 cm              | 2.5 cm                |
| Drive speed                                | 0,8 - 3.2 km/h      | 0,8 - 2.9 km/h      | 0.8 - 2.9 km/h        |
| Gradeability                               | 23 %                | 23 %                | 23 %                  |
| Tilt                                       | 2 °                 | 2 °                 | 2 °                   |
| Lift / lower speed                         | 35 s / 44 s         | 32 s / 42 s         | 58 s / 52 s           |
| Turning radius - outside                   | 2.5 m               | 2.5 m               | 2.5 m                 |
| Non-marking tires                          | 15x5                | 15x5                | 15x5                  |
| Batteries                                  | 24 V - 340 Ah (C20) | 24 V - 340 Ah (C20) | 24 V - 340 Amph (C20) |
| Hydraulic system capacity                  | 25 l                | 25 l                | 27 l                  |
| Weight                                     | 2 030 kg            | 2 330 kg            | 2 470 kg              |

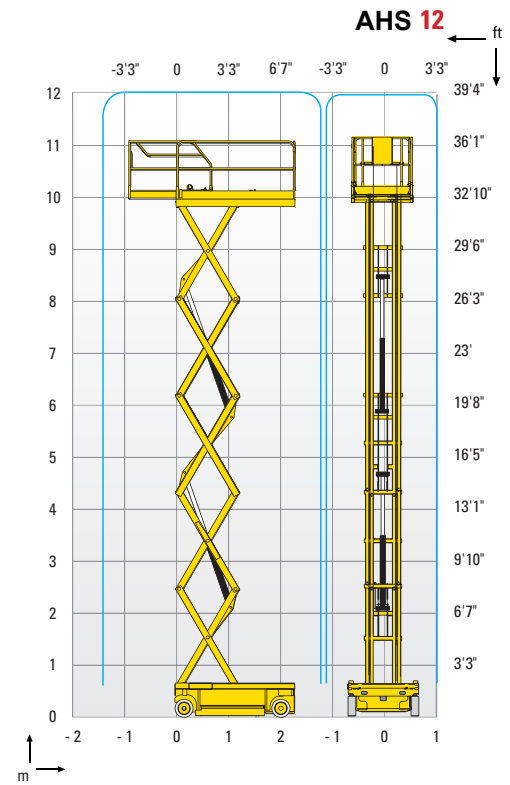
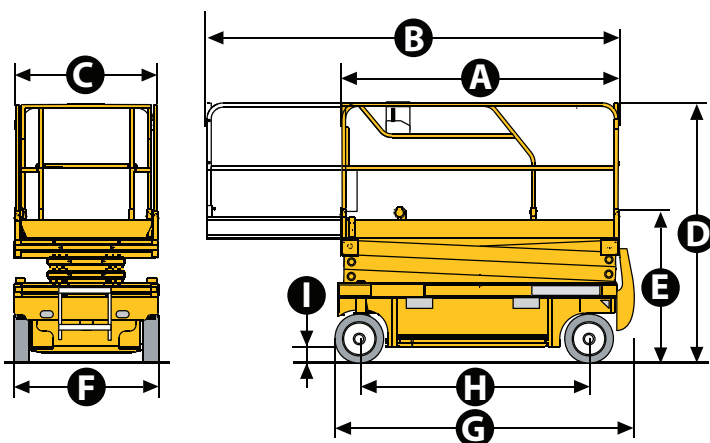

## STANDARD EQUIPMENT

- Pothole guards
- Battery charge indicator
- Proportional lift and drive
- Removable control box in platform
- Swing out component tray
- Battery charger with automatic stop
- Solid non-marking tyres
- Free wheeling device
- Tilt controller
- Load Management System in the platform
- Manual platform lowering valve
- Integrated forklift pockets
- Towing hooks
- Horn
- Hourmeter

## OPTIONS AND ACCESSORIES

- Flashing light
- Travel alarm
- Working light
- Power to platform
- Biodegradable hydraulic oil
- Folding guardrails
- Maintenance-free batteries
- Traction batteries
- Centralised battery filling

### Working At Height Limited

(Southern Office)  
Amberley Court  
Old Elstead Road  
Milford  
Surrey  
GU8 5EB

Tel: 01483 415 410  
Fax: 01483 417 719

### Working At Height Limited

(Northern Office)  
The Portergate  
Ecclesall Road  
Sheffield  
South Yorkshire  
S11 8NX

Tel: 0114 209 6206  
Fax: 0114 209 6001

### Suppliers of:

- Powered Access Platforms
- Aerial Work Platforms
- Runabout Access Platforms
- Scissor Lifts
- Articulating Boom Access Platforms
- Telescopic Boom Access Platforms
- Material Lifts
- Telehandlers
- MEWPS Training