

ROUGH TERRAIN SCISSOR LIFTS



AHS 10 DX AHS 12 DX COMPACT

Outstanding rough terrain driving features

- 4 wheel drive
- Automatic differential lock
- Excellent gradeability (40%)
- Ground clearance of 27 cm

Robust and easy to maintain

- Outriggers positioned within the machine footprint
- Durable and reliable upper control box
- Optimized accessibility to components
- Built-in diagnosis tool

Exceptional productivity

- Full proportional controls
- Narrow turning radius
- One switch to deploy and retract 4 outriggers

WORKING AT HEIGHT

TECHNICAL DATA

	AHS 10 DX	AHS 12 DX
Working height	10.28 m	12.06 m
Platform height	8.28 m	10.06 m
Driveable at full height up to	8.15 m	10.15 m
Lift capacity	565 kg	450 kg
A Length	3.17 m	3.17 m
B Width	1.78 m	1.78 m
C Height - stowed	2.44 m	2.56 m
Storage height	1.59 m	1.7 m
F Platform length	2.45 m	2.45 m
Extended platform length	3.7 m	3.7 m
Platform extension length	1.2 m	1.2 m
G Platform width	1.45 m	1.45 m
D Wheelbase	1.84 m	1.84 m
E Ground clearance	28 cm	28 cm
Number of extensions	1	1
Drive speed	0,8 - 5,5 km/h	0.8 - 5.5 km/h
Turning radius - outside	3.5 m	3.5 m
Lift / lower speed	35 s / 46 s	35 s / 51 s
Engine	18.5 kW - 24.8 hp	18.5 kW - 24.8 hp
Gradeability	40 %	40 %
Tires - foam-filled	26x12-16.5	26x12-16.5
Hydraulic system capacity	75 l	75 l
Weight	3 520 kg	4 110 kg

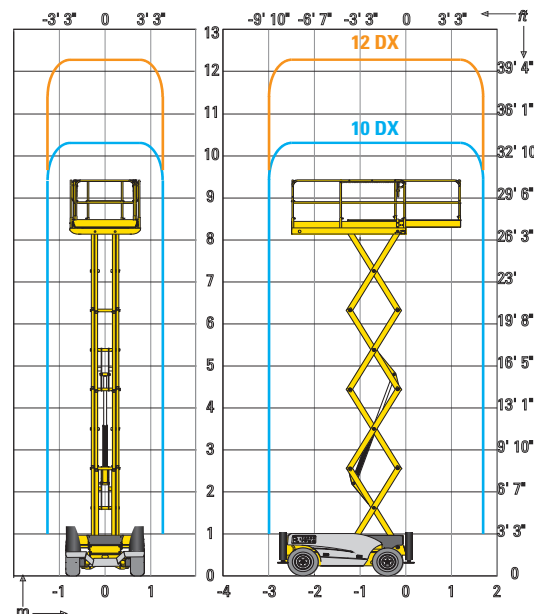
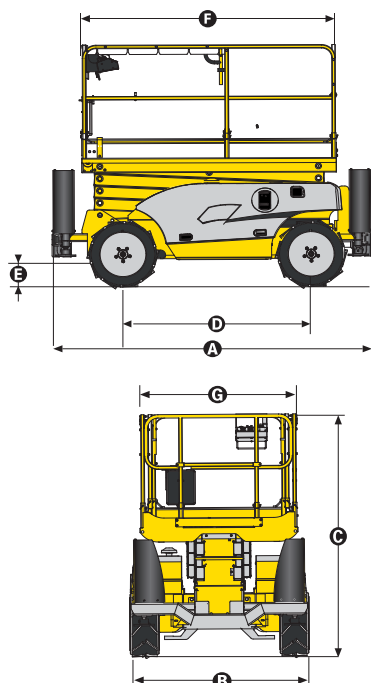

STANDARD EQUIPMENT

- Kubota engine
- 4 wheel drive, 2 wheel steer
- 3° Tilt alarm
- 1,2m platform extension
- 12V - 74 Ah Batteries
- Removable operator's control box
- Brake release
- Hourmeter
- Towing hooks
- Hydraulic brakes
- Manual platform lowering valve
- Foam filled all terrain tyres
- Automatic levelling outriggers
- Side shields
- Horn
- Lanyard attachment points

OPTIONS AND ACCESSORIES

- Non marking tyres
- Rotating beacon
- 110 V power to the platform
- Travel alarm
- Motion alarm for movements and translation
- Working light
- Biodegradable oil
- Cold Weather Package
- Swing-door gate
- Foldable guard-rails
- Hydraulic generator 3.5 kW
- Hydraulic generator 3.5 kW

Working At Height Limited

(Southern Office)
Amberley Court
Old Elstead Road
Milford
Surrey
GU8 5EB

Tel: 01483 415 410
Fax: 01483 417 719

Working At Height Limited

(Northern Office)
The Portergate
Ecclesall Road
Sheffield
South Yorkshire
S11 8NX

Tel: 0114 209 6206
Fax: 0114 209 6001

Suppliers of:

Powered Access Platforms
Aerial Work Platforms
Runabout Access Platforms
Scissor Lifts
Articulating Boom Access Platforms
Telescopic Boom Access Platforms
Material Lifts
Telehandlers
MEWPS Training