



AH6826 SD | AH6832 SD ROUGH TERRAIN SCISSOR LIFTS

The 6826 SD and 6832 SD come equipped with an exclusive cross over symmetrical 4WD system for superior traction. Featuring up to 50% gradeability, these machines can meet the needs of the most challenging job site terrain. Standard features also include an easy to use 1.52 m roll out extension deck, which can be secured in multiple positions for increased platform space and improved reach capabilities. Both Compact models are drivable at full height with the roll out deck fully extended. A low stowed height is ideal for loading and unloading tools and materials.

Featuring robust and reliable design features, the Compact Series Rough Terrain Scissor Lifts utilize standard colour coded and numbered wiring system with analog based controls.



WORKING AT HEIGHT

ROUGH TERRAIN SCISSOR LIFTS

SPECIFICATIONS

AH6826 SD

AH6832 SD

2006/42/CE

| | | |
|--------------------------------------|--------------------|--------------------|
| A Work Height | 9.92 m | 11.75 m |
| B Raised Platform Height | 7.92 m | 9.75 m |
| C Lowered Platform Height | 1.23 m | 1.37 m |
| D Overall Width | 1.72 m | 1.72 m |
| E Overall Length | 2.72 m (†3.35m) | 2.72 m (†3.35m) |
| F Stowed Height (Rails Up) | 2.37 m | 2.51m |
| G Stowed Height (Rails Down) | 1.61 m | 1.75 m |
| H Platform Width (Inside Dimension) | 1.42 m | 1.42 m |
| I Platform Length (Inside Dimension) | 2.44 m | 2.44 m |
| Deck Extension | 1.52 m | 1.52 m |
| Ground Clearance | 0.20 m | 0.20 m |
| Wheelbase | 2.04 m | 2.04 m |
| Weight | 2903 kg (†3305 kg) | 3475 kg (†3655 kg) |
| Gradeability | 50% | 40% |
| Turning Radius (Inside) | 1.52 m | 1.52 m |
| Turning Radius (Outside) | 3.96 m | 3.96 m |
| Lift Time (With Rated Load) | 36 sec | 39 sec |
| Drive Speed (Stowed) | 6.1 km/h | 6.1 km/h |
| Drive Speed (Raised) | 0.6 km/h | 0.6 km/h |
| Maximum Drive Height | Full Height | Full Height |
| Capacity (Overall) | 567 kg | 454 kg |
| Maximum # of Persons | 4 | 4 |

STANDARD FEATURES

- Drivable at full height with roll out deck fully extended
- Crossover symmetrical 4WD
- Multiple wet disc spring applied hydraulic release brakes
- 1.52 m roll out extension deck
- 24hp Kubota Diesel engine
- 90° swing out engine tray
- Analog control system
- Colour coded and numbered wiring system
- Up to 50% Gradeability
- Foam-filled low profile grip lug tyres
- Wiring for AC outlet on platform
- Tilt alarm with drive & lift cut-out
- Overload sensing system
- Lowering warning system
- Operator horn
- Hinged railing system
- Full height spring hinged gate at rear of unit
- Lanyard attachment point
- Scissor guards
- Forklift pockets and tie down/lift lugs

OPTIONS†

- Diesel scrubber
- Independent/auto leveling outriggers (†increases length and weight.)
- Flashing light
- Airline to platform
- 2.0kW hydraulic generator
- Foam-filled non marking tyres (6826 SD only)
- Solid rubber non marking tyres
- All motion audible alarm

† Capacities, and machine weights may differ when options are added

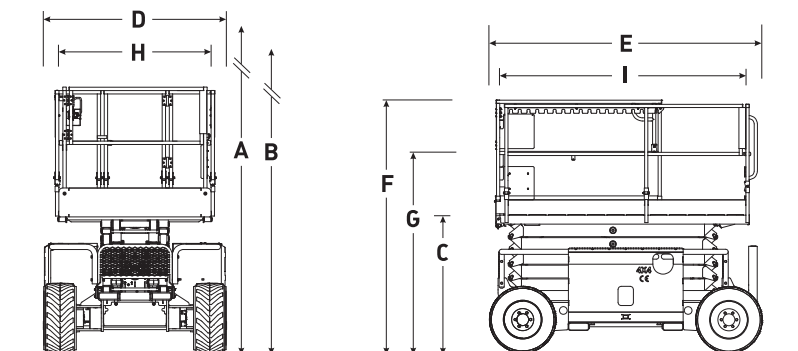

Working At Height Limited

(Southern Office)
Amberley Court
Old Elstead Road
Milford
Surrey
GU8 5EB

Tel: 01483 415 410
Fax: 01483 417 719

Working At Height Limited

(Northern Office)
The Portergate
Ecclesall Road
Sheffield
South Yorkshire
S11 8NX

Tel: 0114 209 6206
Fax: 0114 209 6001

Suppliers of:

Powered Access Platforms
Aerial Work Platforms
Runabout Access Platforms
Scissor Lifts
Articulating Boom Access Platforms
Telescopic Boom Access Platforms
Material Lifts
Telehandlers
MEWPS Training