



AH3215 SE AH3219 SE DC ELECTRIC SCISSOR LIFTS

The Compact Series DC Electric Scissor Lifts offers an easy to service, low maintenance design in a compact and versatile package. Equipped with variable speed front wheel hydraulic drive, and 90° steering, both models in the Compact Series are capable of maneuvering in the smallest spaces. Featuring a 0.91 m roll out extension deck, these Compact Series models offer work heights up to 7.79 m and up to 30% gradeability.

The Compact Series feature durable steel swing-out component trays, providing unrestricted access for easy maintenance and service. Consistent with The robust and reliable design features, the Compact Series DC Electric Scissor lifts utilizes standard colour coded and numbered wiring system with analog based controls.



WORKING AT HEIGHT

AH 3215 SE AH 3219 SE

DC ELECTRIC SCISSOR LIFTS

SPECIFICATIONS	AH3215 SE	AH3219 SE
A Work Height	6.57 m	7.79 m
B Raised Platform Height	4.57 m	5.79 m
C Lowered Platform Height	0.88 m	0.99 m
D Overall Width	0.81 m	0.81 m
E Overall Length	1.78 m	1.78 m
F Stowed Height (Rails Up)	1.88 m	1.99 m
G Stowed Height (Rails Down)	1.53 m	1.64 m
H Platform Width (Inside Dimension)	0.66 m	0.66 m
I Platform Length (Inside Dimension)	1.63 m	1.63 m
Extension Deck (Roll Out)	0.91 m	0.91 m
Ground Clearance (Stowed)	6.03 cm	6.03 cm
Ground Clearance (raised)	1.78 cm	1.78 cm
Wheelbase	1.40 m	1.40 m
Weight	1120 kg	1312 kg
Gradeability	30%	25%
Turning Radius (Inside)	0	0
Turning Radius (Outside)	1.68 m	1.68 m
Lift Time (With Rated Load)	22 sec	21 sec
Drive Speed (Stowed)	3.7 km/h	3.7 km/h
Drive Speed (Raised)	1.1 km/h	1.1 km/h
Maximum Drive Height	Full Height	Full Height
Capacity (Overall)	227 kg	227 kg
Maximum # of Persons	2	2

2006/42/CE

STANDARD FEATURES

- Drivable at full height
- Variable speed, front two wheel hydraulic drive
- 90° steering (zero inside turning radius)
- Dual holding brakes
- Proportional controls for drive & lift functions
- 0.91 m roll out extension deck
- 24V DC power source
- Low voltage battery protection
- Analog control system
- Colour coded and numbered wiring system
- Up to 30% gradeability
- Solid rubber, non-marking tyres
- Pothole protection system
- Wiring for AC outlet on platform
- Tilt alarm with drive & lift cut-out
- Overload sensing system
- Lowering warning system
- Operator horn
- Half height spring hinged gate
- Lanyard attachment points
- Forklift pockets and tie down/lift lugs

OPTIONS†

- Flashing light
- Airline to platform
- Hinged railing system
- Full height spring hinged gate*
- All motion audible alarm
- Pipe racks
- Drywall/board carrier

*not available with hinged railing system

† Capacities, and machine weights may differ when options are added

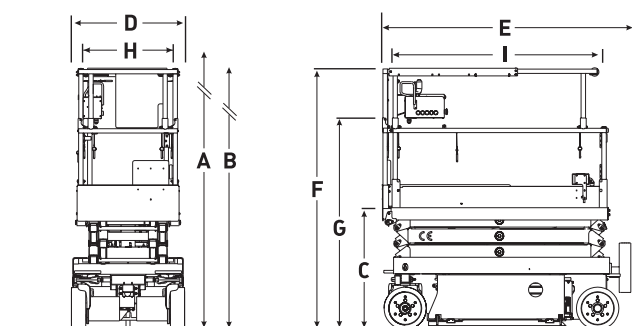

Working At Height Limited

(Southern Office)
Amberley Court
Old Elstead Road
Milford
Surrey
GU8 5EB

Tel: 01483 415 410
Fax: 01483 417 719

Working At Height Limited

(Northern Office)
The Portergate
Ecclesall Road
Sheffield
South Yorkshire
S11 8NX

Tel: 0114 209 6206
Fax: 0114 209 6001

Suppliers of:

Powered Access Platforms
Aerial Work Platforms
Runabout Access Platforms
Scissor Lifts
Articulating Boom Access Platforms
Telescopic Boom Access Platforms
Material Lifts
Telehandlers
MEWPS Training