

ELECTRIC SCISSOR LIFTS

AHS 8 OPTIMUM

Best driving and lifting experience

- AC powered
- High precision driving
- Proportional and quick movements
- Best turning radius

Utmost versatility

- Ability to go through standard doorways
- Mobile potholes protection
- Indoor - Outdoor rated

Minimal maintenance and downtime

- Maintenance free AC motors
- Easy access
2 swing out trays
- Haulotte ACTIV'Screen (onboard diagnostic)
- Smart transportability

Longer life time

- Extreme robustness
- Optimized total cost of ownership
- Upgraded residual value



WORKINGATHEIGHT

ELECTRIC SCISSOR LIFTS

TECHNICAL DATA

AHS 8 OPTIMUM

| | |
|--------------------------------------------|----------------------|
| Working height | 7.77 m |
| Platform height | 5.77 m |
| Driveable at full height up to | 5.77 m |
| Lift capacity - inside | 230 kg |
| Lift capacity - outside | 230 kg |
| A Platform length - outside | 1.73 m |
| B Platform length - extended | 2.59 m |
| Length - extension | 0.86 m |
| C Platform width - outside | 0.74 m |
| D Height - stowed | 1.99 m |
| E Overall width | 0.79 m |
| F Length | 1.9 m |
| G Wheelbase | 1.38 m |
| H Ground clearance - Center | 8.7 cm |
| Ground clearance - Pothole guards deployed | 2 cm |
| Drive speed | 0.5 - 5.0 km/h |
| Gradeability | 25 % |
| Tilt | 1.5° - 3° |
| Lift / lower speed | 20 s / 18 s |
| Turning radius - outside | 1.5 m |
| Non-marking tires | 12.5 x 4.13 |
| Batteries | 24 V - 105 Amph (C5) |
| Hydraulic system capacity | 6 l |
| Weight | 1 530 kg |

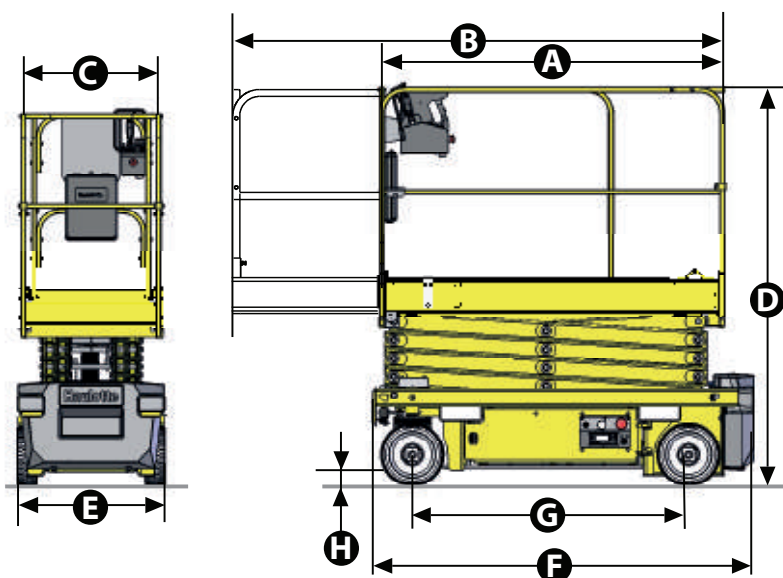
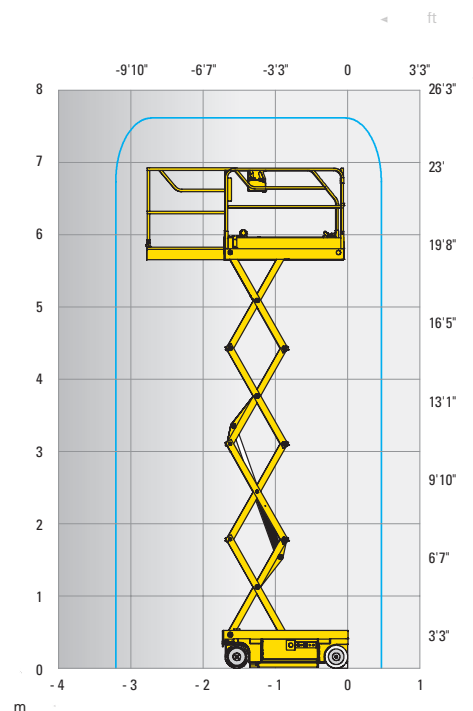

STANDARD EQUIPMENT

- 24 V electric drive Brushless AC motors
- 24 V - 105 Ah C5 batteries
- Battery charge indicator
- Battery level indicator on upper and lower control boxes
- Haulotte Activ'Screen (battery charge, Hourmeter, service alert & failures icons in code or in full text...)
- 2 swing out trays
- Lateral fork lifting pockets
- Electric or manual break release system
- lifting and stowage points
- Non marking tires

OPTIONS AND ACCESSORIES

- Maintenance free gel batteries
- Pipe cradle
- Swing door entry gate
- Flashing light
- Dual flashing lights
- Working light
- AC power to platform
- Additional battery cut-off
- Hydraulic oil for cold countries

Working At Height Limited

(Southern Office)
Amberley Court
Old Elstead Road
Milford
Surrey
GU8 5EB

Tel: 01483 415 410
Fax: 01483 417 719

Working At Height Limited

(Northern Office)
The Portergate
Ecclesall Road
Sheffield
South Yorkshire
S11 8NX

Tel: 0114 209 6206
Fax: 0114 209 6001

Suppliers of:

Powered Access Platforms
Aerial Work Platforms
Runabout Access Platforms
Scissor Lifts
Articulating Boom Access Platforms
Telescopic Boom Access Platforms
Material Lifts
Telehandlers
MEWPS Training