



AH21TB 0 AH21TB PRO



Outstanding performance

- 20.6 m working height
- 15.9 m maximum outreach

Optimal productivity

- Best lifting speed 56 sec
- Fully proportional and simultaneous movements

Best comfort and safety feeling

- Rigid boom
- Single control for both steering axles

Optimized maintenance time

- Easy access to all components
- Easy boom maintenance
- Exclusive modular basket, easy and quick to repair
- Activ'Shfield™ Bar (PRO model)



WORKING AT HEIGHT



AH21TB 0 / TB PRO

ROUGH TERRAIN TELESCOPIC BOOMS

TECHNICAL DATA

	AH21 TB 0	AH21 TB PRO
Working height	20.6 m	20.6 m
Platform height	18.6 m	18.6 m
Horizontal outreach	15.9 m	15.9 m
Lift capacity	230 kg (2 persons)	230 kg (2 persons)
F x G Platform size	2.44 x 0.91 m	2.44 x 0.91 m
A Length - stowed	9 m	9 m
B Width	2.47 m	2.47 m
C Height - stowed	2.7 m	2.7 m
Platform rotation	175° (+85/-90)	175° (+85/-90)
Boom rotation angle	90° (+75/-15)	90° (+75/-15)
Turntable rotation	360° continuous	360° continuous
Tailswing	109 cm	109 cm
D Wheelbase	2.5 m	2.5 m
E Ground clearance	34 cm	34 cm
Tilt	5°	5°
Drive speed	0.5 - 6.5 km/h	0.5 - 6.5 km/h
Gradeability	40 %	40 %
Turning radius - outside	6,3 m	3,4 m
Tires - foam-filled	385/65 - 22.5	385/65 - 22.5
Engine	Kubota 36.5 kW - 48.9 hp	Kubota 36.5 kW - 48.9 hp
Weight	11 340 kg	11 420 kg

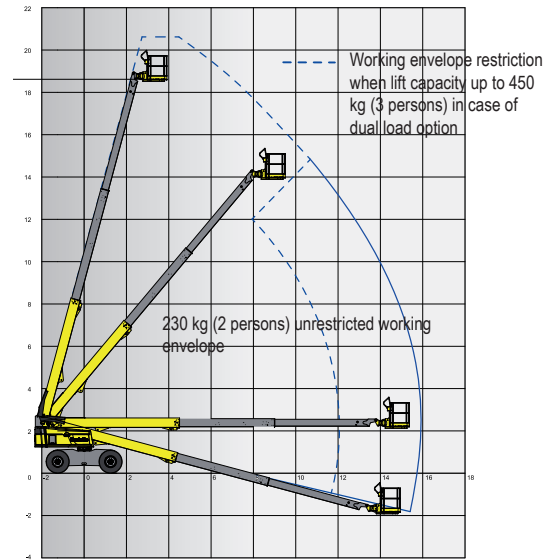
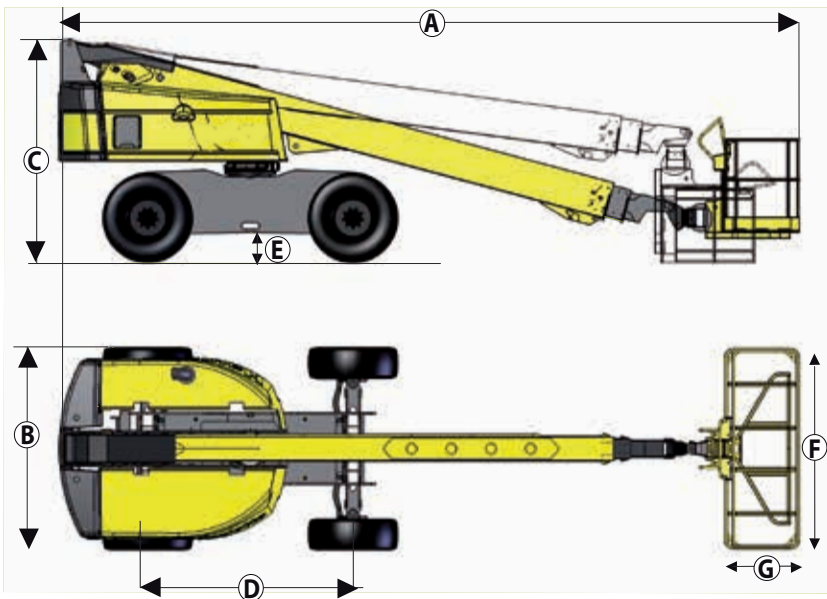

STANDARD EQUIPMENT

- 4 wheel drive / 2 (0) or 4 (PRO) wheel steer
- Automatic differential wheel lock increase rough terrain capacity
- Front oscillating axle increases stability on uneven ground
- Proportional controls enhance comfort and safety
- 4 simultaneous movements for maximum productivity
- 230 kg / 500 lbs load capacity unrestricted working envelope
- Large modular basket 2.44 x 0.91 m, Drop entry gate
- Upper control box protection cover and tool tray in plastic ultra-solid
- Prepared for power to platform 110 / 230 V
- Diagnostic display for fault and service alerts
- Swing out engine tray for ease of maintenance
- Hour meter
- Low fuel level indicator (upper control box)
- Engine pre-heater with light indicator
- Sound and light alarm for tilt and load
- Maximum wind speed 45 km/h / 28 mph
- 12 V battery
- Electric pump system and emergency descent
- Boom maintenance (extension system, upper pads replacement) without disassembly
- Travel alarm
- Activ' Shield™ Bar PRO model (for Europe and Latin America)

OPTIONS AND ACCESSORIES

- Dual load capacity 230 / 450 kg (2 / 3 persons)
- 3.5 kW hydraulic generator
- Narrow modular platform: 1.83 m x 0.8 m
- Lateral Swing door entry gate
- Power to platform (Female plug in the basket with or without circuit-breaker 30mA)
- Air line to platform 13 mm inner diameter
- Rotating beacon
- Work lights
- Biodegradable hydraulic oil
- Cold weather package
- Warm environment package
- 60 km/h wind speed - 37 mph

WORKING AT HEIGHT