



# HA18 X

## Optimal productivity

- Full proportional controls and simultaneous boom functions
- Lifts to full height in 44 seconds

## Outstanding rough terrain driving features

- 4 wheel drive means greater manoeuvrability
- Hydraulic differential lock
- 38 cm ground clearance

**10.6 metre outreach provides a large working envelope**



**WORKING AT HEIGHT**





# HA18 X



## ROUGH TERRAIN ARTICULATING BOOMS

### TECHNICAL DATA

### HA18 X

Working height	17.3 m
Platform height	15.3 m
Horizontal outreach	10.6 m
Up and over clearance	6.5 m
Lift capacity	230 kg
<b>F</b> x <b>G</b> Platform size	1.8 x 0.8 m
<b>A</b> Length - stowed	7.5 m
Transport length	5.8 m
<b>B</b> Width	2.3 m
<b>C</b> Height - stowed	2.2 m
Transport height	2.55 m
Vertical jib rotation	140° (+70/-70)
Platform rotation	180° (+90/-90)
Turntable rotation	350°
Tailswing	0 m
<b>D</b> Wheelbase	2 m
<b>E</b> Ground clearance	38 cm
Tilt	5°
Drive speed	0.8 - 5.5 km/h
Gradeability	40 %
Turning radius - outside	4.5 m
Tires - foam-filled	14-17.5
Power source	31.2 kW - 42.4 hp
Hydraulic system capacity	100 l
Fuel tank capacity	72 l
Weight	7 700 kg

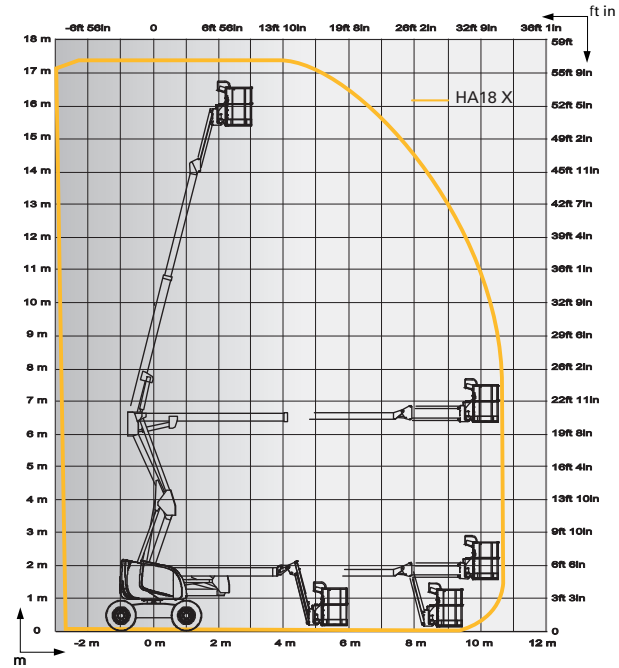
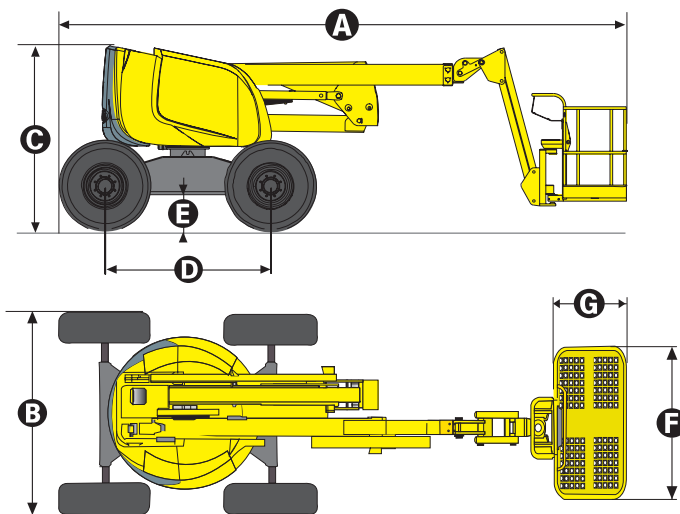

### STANDARD EQUIPMENT

- 4 wheel drive (2 wheel steer)
- 350° turntable
- Safe to use in winds up to 45 km/h
- Swing out engine tray for ease of maintenance
- 72 l fuel tank; 1.50 m filling height
- 5° tilt alarm
- 12 V battery / electrical control system
- Auxiliary power in the platform for emergency descent
- Brake release
- Hourmeter
- Slewing block pin
- Towing hooks / lifting eyes

### OPTIONS AND ACCESSORIES

- 3.3 kW on-board generator
- Power to platform
- Large basket 2.3 x 0.80 m
- Travel alarm
- Rotating beacon
- Working light
- Catalytic exhaust
- Biodegradable hydraulic oil
- Cold Weather Package
- Warm environment kit
- Air line in platform

