



Optimal productivity

- Continuous 360° turntable rotation
- Full proportional controls and simultaneous boom functions
- Lifts to full height in 44 seconds

Outstanding rough terrain driving features

- 4 wheel steer and 4 wheel drive mean greater manoeuvrability
- Hydraulic differential lock
- 40cm ground clearance

10.6 metre outreach provides a large working envelope



WORKING AT HEIGHT



AH18



ROUGH TERRAIN ARTICULATING BOOMS

TECHNICAL DATA

AH18

Working height	17.3 m
Platform height	15.3 m
Horizontal outreach	10.6 m
Up and over clearance	6.6 m
Lift capacity	230 kg
F x G Platform size	1.8 x 0.8 m
A Length - stowed	7.6 m
Transport length	5.9 m
B Width	2.3 m
C Height - stowed	2.3 m
Transport height	2.6 m
Vertical jib rotation	140° (+70/-70)
Platform rotation	180° (+90/-90)
Turntable rotation	360°
Tailswing	0 m
D Wheelbase	2 m
E Ground clearance	40 cm
Tilt	5°
Drive speed	0.8 - 5.5 km/h
Gradeability	50 %
Turning radius - outside	3.75 m
Tires - foam-filled	385/65-22.5
Power source	31 kW - 42 hp
Hydraulic system capacity	100 l
Fuel tank capacity	72 l
Weight	7 935 kg

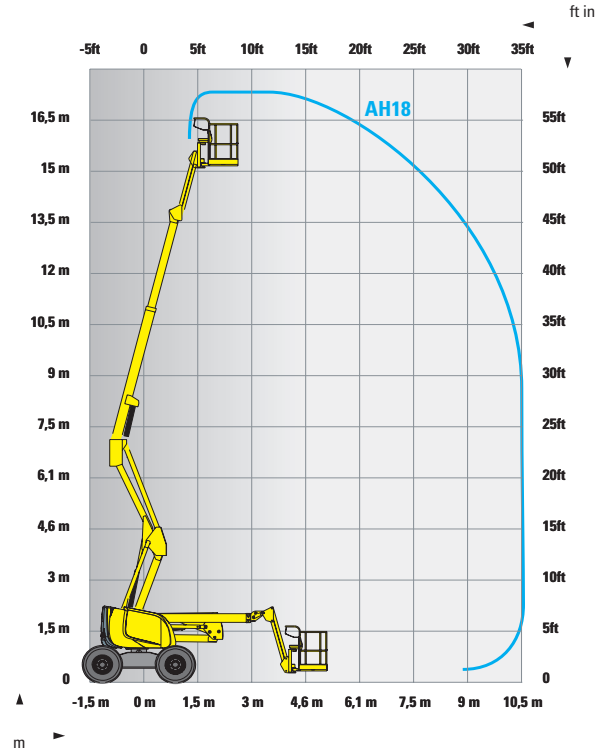
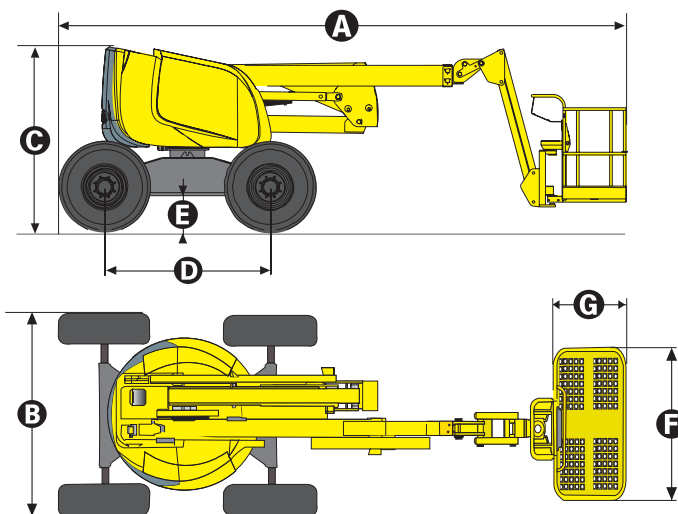

STANDARD EQUIPMENT

- 4 wheel drive and steer
- Continuous 360° turntable
- Safe to use in winds up to 60km/h
- Swing out engine tray for ease of maintenance
- 72 l fuel tank; 1.50 m filling height
- 5° tilt alarm
- 12 V battery / electrical control system
- Auxiliary power in the platform for emergency descent
- Brake release
- Hourmeter
- Slewing block pin
- Towing hooks / lifting eyes

OPTIONS AND ACCESSORIES

- 3.3 kW on-board generator
- Power to platform
- Large basket 2.3 x 0.80 m
- Travel alarm
- Rotating beacon
- Working light
- Catalytic exhaust
- Biodegradable hydraulic oil
- Cold Weather Package
- Warm environment kit
- Air line in platform

