



## Performance & Ease of use

- Industry leading working envelope with an outreach of 8.3 m
- Best lifting speed of 40 sec
- Fully proportional and simultaneous movements
- 4-wheel steer and 360° continuous rotation for a greater productivity

## Excellent Robustness

- Rugged hoods with ergonomic handle
- Long lasting structural design

## Easy Maintenance

- Fully modular basket with upper control box cover
- Easy access to all components
- Self-diagnosis tool on lower control box

## Best Comfort and Safety Feeling

- Safe driving
- Activ'Shield© Bar



**WORKING AT HEIGHT**



# AH16 JRT PRO



## ROUGH TERRAIN ARTICULATING BOOMS

### TECHNICAL DATA

### AH16 JRT PRO

4WD/4WS  
Front oscillating axle

Working height	16 m
Platform height	14 m
Horizontal outreach	8.3 m
Up and over clearance	7.65 m
Lift capacity	230 kg (2 persons)
<b>F</b> x <b>G</b> Platform size	1.83 x 0.80 m
<b>A</b> Length - stowed	6.75 m
<b>H</b> Transport length (jib tucked under)	5.05 m
<b>B</b> Width	2.3 m
<b>C</b> Height - stowed	2.3 m
<b>I</b> Transport height	2.4 m
Jib length	1.2 m
Vertical jib rotation	140° (-80°/+60°)
Platform rotation	165° (-75°/+90°)
Turntable rotation	360° continuous
<b>D</b> Wheelbase	2.1 m
<b>E</b> Ground clearance	38 cm
Tilt	5°
Drive speed	Up to 5.6 km/h
Gradeability	40 %
Turning radius - outside	3.75 m
Tires cured on solid Rough Terrain	14x17.5
Power source	Kubota 26 kW - 35 hp
Hydraulic system capacity	76 l
Fuel tank capacity	62 l
Weight	6 650 kg

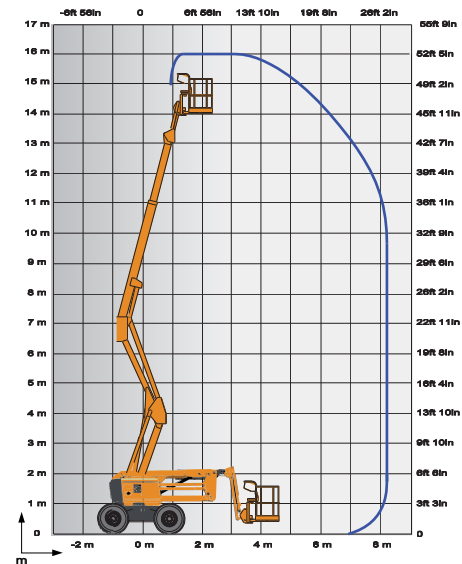

### STANDARD EQUIPMENT

- 4 wheel drive
- 4 wheel steer
- Front oscillating axle increases stability on uneven ground
- Permanent limited slip differential
- 230 kg (2 persons) load capacity
- 4 simultaneous movements for maximum productivity
- Safe to use in winds up to 60km/h - 37mph
- Rotating beacon
- Modular standard basket 1.83 m x 0.80 m, quick & easy to repair
- Drop bar entry gate
- Upper control box cover
- Tool tray
- AC power to platform (110/230V)
- Self-diagnosis tool on lower control box
- Swing out engine tray for ease of maintenance
- Hour meter
- Low fuel level indicator (upper & lower control boxes)
- Engine pre-heater with light indicator
- Sound and light alarm for tilt and load
- 12 V battery / electrical control system
- Electric pump system and emergency descent
- Travel alarm
- ActivShield© Bar : Exclusive secondary guarding device (Europe only)

### OPTIONS AND ACCESSORIES

- Modular large basket 2.44 m x 0.91 m quick and easy to repair
- Lateral swing door entry gate
- Hydraulic generator Dynaset 3.5Kw
- Air-line to platform 6.5 mm inner diameter
- 70W working light
- Power to platform (Female plug in the basket with or without circuit-breaker 30mA)
- Flashing light
- Cold weather kit : -10°C / -25°C
- Hot weather kit : hydraulic oil cooler + hydraulic oil
- Biodegradable hydraulic oil
- Large cured on solid Rough terrain tires 385/65
- Non-marking tires 14x17.5
- Catalytic exhaust for diesel engine
- Spark arrestor and electric one-way valve
- Battery cut-off

