



AH16 JRT AH16 JRT 0

Performance & Ease of use

- Industry leading working envelope with an outreach of 8.3 m
- Best lifting speed of 40 sec
- Fully proportional and simultaneous movements
- Ease of transport

Excellent Robustness

- Rugged hoods with ergonomic handle
- Long lasting structural design

Easy Maintenance

- Fully modular basket with upper control box cover
- Easy access to all components
- Self-diagnosis tool on lower control box

Best Comfort and Safety Feeling

- Safe driving



WORKINGATHEIGHT





AH16 JRT / AH16 JRT O

ROUGH TERRAIN ARTICULATING BOOMS

TECHNICAL DATA

AH16 JRT 4WD / 2WS
AH16 JRT O 4WD / 2WS
 Front oscillating axle

Working height	16 m
Platform height	14 m
Horizontal outreach	8.3 m
Up and over clearance	7.65 m
Lift capacity	230 kg (2 persons)
F x G Platform size	1.83 x 0.80 m
A Length - stowed	6.75 m
H Transport length (jib tucked under)	5.05 m
B Width	2.3 m
C Height - stowed	2.3 m
I Transport height	2.4 m
Jib length	1.2 m
Vertical jib rotation	140° (-80°/+60°)
Platform rotation	165° (-75°/+90°)
Turntable rotation	355° non continuous
D Wheelbase	2.1 m
E Ground clearance	38 cm
Tilt	5 °
Drive speed	Up to 5.6 km/h
Gradeability	40 %
Turning radius - outside	4.5 m
Tires cured on solid Rough Terrain	14x17.5
Power source	Kubota 26 kW - 35 hp
Hydraulic system capacity	76 l
Fuel tank capacity	62 l
Weight	6 200 kg 6 600 kg

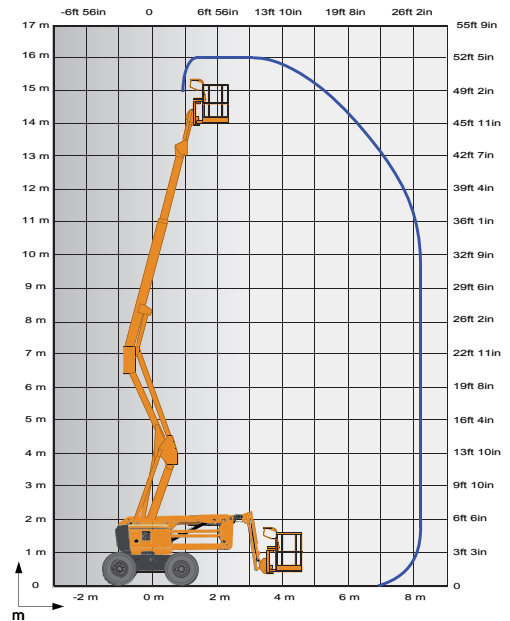
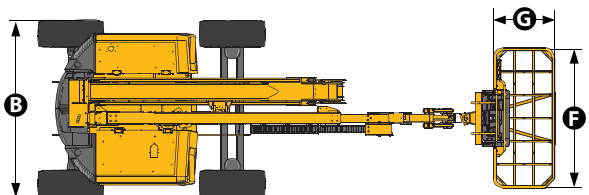
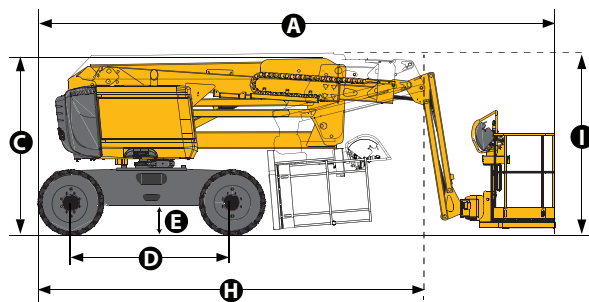

STANDARD EQUIPMENT

- 4 wheel drive
- 2 wheel steer
- Front oscillating axle (JRT O) increases stability on uneven ground
- Permanent limited slip differential
- 230 kg (2 persons) load capacity
- 4 simultaneous movements for maximum productivity
- Safe to use in winds up to 60km/h - 37mph
- Rotating beacon
- Modular standard basket 1.83 m x 0.80 m, quick & easy to repair
- Drop bar entry gate
- Upper control box cover
- Tool tray
- AC power to platform (110/230V)
- Self-diagnosis tool on lower control box
- Swing out engine tray for ease of maintenance
- Hour meter
- Low fuel level indicator (upper & lower control boxes)
- Engine pre-heater with light indicator
- Sound and light alarm for tilt and load
- 12 V battery / electrical control system
- Electric pump system and emergency descent
- Travel alarm

OPTIONS AND ACCESSORIES

- Modular large basket 2.44 m x 0.91 m quick and easy to repair
- Lateral swing door entry gate
- Hydraulic generator Dynaset 3.5Kw
- Air-line to platform 6.5 mm inner diameter
- 70W working light
- Power to platform (Female plug in the basket with or without circuit-breaker 30mA)
- Flashing light
- Cold weather kit : -10°C / -25°C
- Hot weather kit : hydraulic oil cooler + hydraulic oil
- Biodegradable hydraulic oil
- Large cured on solid Rough terrain tires 385/65
- Non-marking tires 14x17.5
- Haulotte Activ'Shield© Bar : Exclusive secondary guarding device
- Catalytic exhaust for diesel engine
- Spark arrestor and electric one-way valve
- Battery cut-off

