



## AH45 TB TELESCOPIC BOOM LIFT

The robust and reliable **AH45 TB** boom offers the lowest life cycle costs, proven reliability, and ease of serviceability. Superior terrainability is obtained utilizing an axle based 4WD system offering unsurpassed traction and terrainability; using a 'No Spin' differential on the rear axle and limited slip differential on the front oscillating axle. Other competitive advantages include an innovative and intuitive direction sensing drive and steer control system which ensures the boom lift will always drive and steer with respect to the operator rather than the orientation of the chassis.

Standard color coded and numbered wiring system, along with proven relay based controls, complete a well rounded package of superior, proven, operating characteristics.



**WORKINGATHEIGHT**

# TELESCOPIC BOOM LIFT

## SPECIFICATIONS

## AH45 TB

2006/42/CE

Work Height	15.77 m
Platform Height	13.77 m
Horizontal Reach	12.12 m
Platform Size	0.9 x 2.4 m
Stowed Width	2.29 m
Tailswing	0.94 m
Stowed Height	2.39 m
Stowed Length	8.79 m
Wheelbase	2.29 m
Ground Clearance	0.28 m
Platform Rotation	180°
Jib Length	1.52 m
Jib Range +/-	63° / 66°
Weight	7,552 kg
Gradeability - 4WD	45%
Turning Radius (Inside) - 4WD	2.13 m
Turning Radius (Outside) - 4WD	5.02 m
Axle Oscillation	0.20 m
Drive Speed (stowed)	7.2 km/h
Drive Speed (raised)	0.8 km/h
Capacity	227 kg
Maximum # of Persons	2

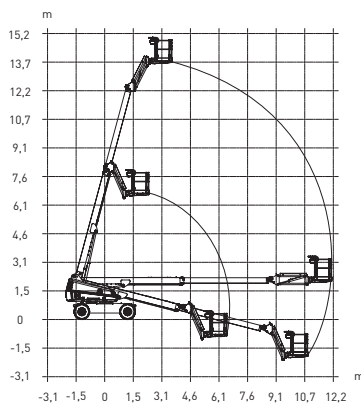

## STANDARD FEATURES

- Drivable at full height
- Axle based 4WD
- "No Spin" differential and limited slip front differential
- Oscillating axle
- Wet disc SAHR brakes (rear axle)
- 48hp Deutz diesel engine
- Swing out engine tray
- Swing up fiberglass cowlings
- 360° continuous turret rotation
- Direction sensing drive and steer controls
- Proportional controls
- Relay based control system
- Colour coded and numbered wiring system
- 45% gradeability
- Grip lug foam-filled tyres
- Wiring for AC outlet on platform
- Tilt alarm with drive cut-out
- Overload sensing system
- Operator horn
- Modular platform railing system
- Spring hinged gate
- Lanyard attachment points
- Tie down/lifting lugs

## OPTIONS†

- 3.5kW generator (Includes hydraulic oil cooler)
- Cold weather start kit (Diesel only)
- Diesel scrubber
- Hydraulic oil cooler
- Flashing light
- Platform work lights
- Airline to platform
- 2WD
- All motion alarm

† Capacities, and machine weights may differ when options are added

### Working At Height Limited

(Southern Office)  
Amberley Court  
Old Elstead Road  
Milford  
Surrey  
GU8 5EB

Tel: 01483 415 410  
Fax: 01483 417 719

### Working At Height Limited

(Northern Office)  
The Portergate  
Ecclesall Road  
Sheffield  
South Yorkshire  
S11 8NX

Tel: 0114 209 6206  
Fax: 0114 209 6001

### Suppliers of:

Powered Access Platforms  
Aerial Work Platforms  
Runabout Access Platforms  
Scissor Lifts  
Articulating Boom Access Platforms  
Telescopic Boom Access Platforms  
Material Lifts  
Telehandlers  
MEWPS Training