



AH15 EB

Excellent manoeuvrability in the tightest spaces

- Compact size with 1.5 m width
- 2m stowed height can pass through a standard doorway
- 130° (+65°/-65°) fly jib range of motion
- Tight turning radius (3,9m)

Optimal productivity and comfort

- 8.65 m outreach
- Long working cycles
- Full proportional controls

Robust, reliable and easy to maintain



WORKING AT HEIGHT





AH15 EB

ELECTRIC ARTICULATING BOOMS

TECHNICAL DATA

AH15 EB

Working height	14.87 m
Platform height	12.87 m
Horizontal outreach	8.65 m
Up and over clearance	6.25 m
Lift capacity	230 kg
Vertical jib rotation	130° (+65/-65)
A Length	6.65 m
B Width	1.52 m
C Height - stowed	2.1 m
Height - transport	3.02 m
D Wheelbase	2 m
E Ground clearance	14 cm
F x G Platform size	1.15 x 1.07 m
Tailswing	0 cm
Proportional drive speed	0.7 - 4.5 km/h
Turning radius - outside	3.95 m
Turntable rotation	355°
Platform rotation	180° (+90/-90)
Energy	48 V - 345 Amph (C5)
Gradeability	25 %
Tyres - non marking	23x10-12
Hydraulic system capacity	30 l
Weight	7 230 kg

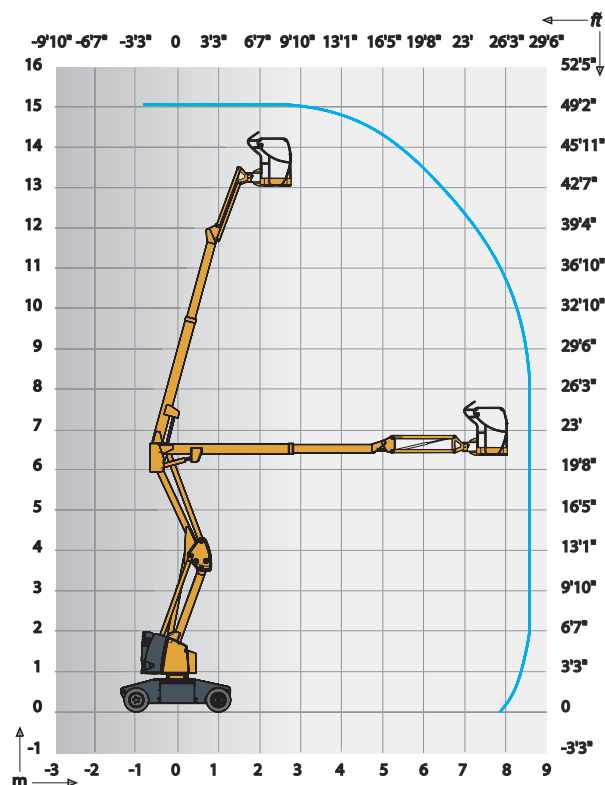
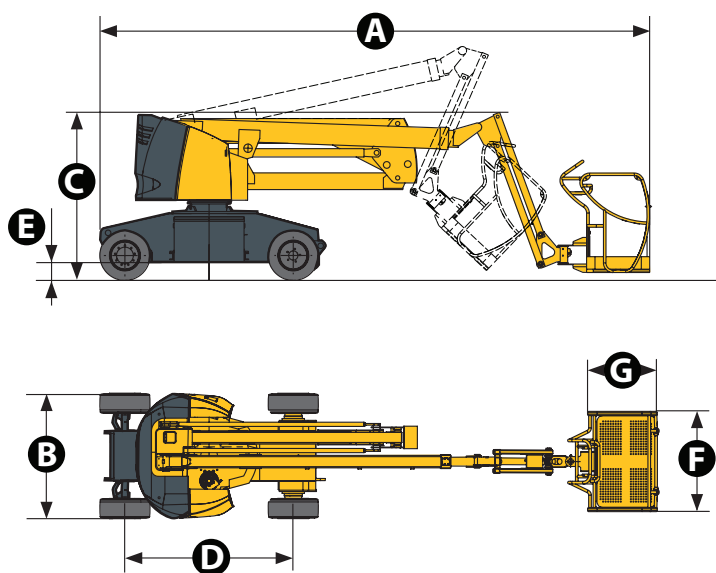

STANDARD EQUIPMENT

- Semi-traction battery
- Battery charge indicator
- 48 V – 50 A battery charger
- Sensitive control box
- 3° Tilt alarm
- Non marking tyres
- Outside / inside use: wind rated to 45 km/h
- Brake release
- Hourmeter
- Slewing block pin
- Towing hooks and lifting eyes
- Emergency hand pump
- 2 wheel drive and steer
- Load limiter in cage
- Horn

OPTIONS AND ACCESSORIES

- Flashing light
- Power to platform
- Travel alarm
- Centralised battery filling
- 360 Ah traction batteries
- Waterproof batteries
- Air line to cage
- Electric remote brake release
- Biodegradable oil
- Large basket option (1,5m x 0,8m)

Working At Height Limited

(Southern Office)
Amberley Court
Old Elstead Road
Milford
Surrey
GU8 5EB

Tel: 01483 415 410
Fax: 01483 417 719

Working At Height Limited

(Northern Office)
The Portergate
Ecclesall Road
Sheffield
South Yorkshire
S11 8NX

Tel: 0114 209 6206
Fax: 0114 209 6001

Suppliers of:

Powered Access Platforms
Aerial Work Platforms
Runabout Access Platforms
Scissor Lifts
Articulating Boom Access Platforms
Telescopic Boom Access Platforms
Material Lifts
Telehandlers
MEWPS Training