



AH 12 C

AH 12 C+

Excellent manoeuvrability in the tightest spaces

- Drive and turntable rotation
- Tight turning radius
- Zero tailswing
- Compact stowed height passes through standard doorways
- 1.20m width

Optimized productivity

- Proportional and simultaneous movements
- Suitable for inside and outside use
- Long working cycles



ELECTRIC ARTICULATING BOOMS

TECHNICAL DATA

AH12C

AH12C+

Working height	11.68 m	11.68 m
Platform height	9.68 m	9.68 m
Horizontal outreach	6.94 m	7.22 m
Up and over clearance	4.74 m	4.74 m
Lift capacity	250 kg	200 kg
F x G Platform size	1.14 x 0.8 m	1.14 x 0.8 m
A Length	5.36 m	5.64 m
B Width	1.2 m	1.2 m
C Height - stowed	1.99 m	1.99 m
H Length – transport	3.86 m	4.2 m
J Height - transport	2.22 m	2.6 m
Tailswing	0 cm	0 cm
Horizontal jib rotation	N/A	180° (-90/+90)
Vertical jib rotation	132.2° (+63.5/-68.7)	132.2° (+63.5/-68.7)
Platform rotation	180° (+90/-90)	180° (-90/+90)
Turntable rotation	355 °	355 °
D Wheelbase	1.65 m	1.65 m
E Ground clearance	10.7 cm	10.7 cm
Tilt	3°	3°
Proportional drive speed	0.68 - 6 km/h	0.68 - 6 km/h
Gradeability	25 %	25 %
Turning radius - outside	3.65m	3.65 m
Tyres - non marking	598x190	598x190
Energy	48 V - 320 Amph (C5)	48V - 320 Amph (C5)
Weight	7 065 kg	7 110 kg

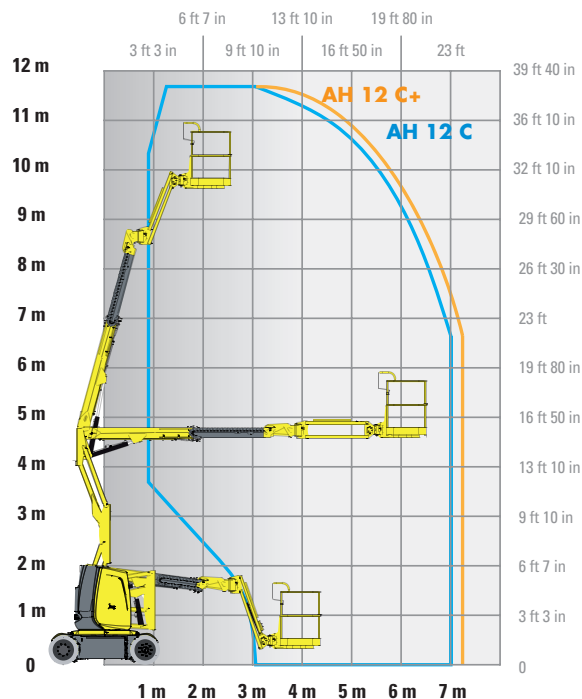

STANDARD EQUIPMENT

- Ergonomic control panels
- Battery charge indicators on both control panels
- Automatic platform levelling
- Solid non-marking tyres
- 2 wheel drive
- 2 wheel steer
- Deep cycle batteries
- On board battery charger 48V - 50A
- Safe to use in winds up to 45km/h
- Towing hooks and lifting eyes
- Tilt sensor
- Load Management System in the platform
- Horn
- Hourmeter
- Mechanical turret slewing lock
- Emergency hand pump

OPTIONS AND ACCESSORIES

- Traction batteries
- Auxiliary power in the platform for emergency descent
- Air line to platform
- Fluorescent tube caddy
- Orange safety cones holder
- Self-closing swing door
- Flashing light
- Working light
- Electric socket in the platform
- Circuit-breaker
- Fluorescent tube caddy
- Fluorescent tube caddy

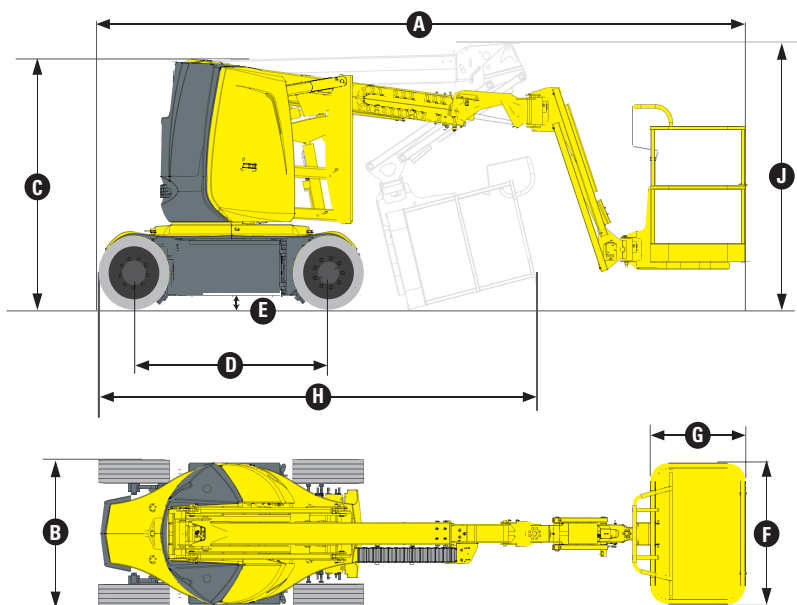

Working At Height Limited

(Southern Office)
Amberley Court
Old Elstead Road
Milford
Surrey
GU8 5EB

Tel: 01483 415 410
Fax: 01483 417 719

Working At Height Limited

(Northern Office)
The Portergate
Ecclesall Road
Sheffield
South Yorkshire
S11 8NX

Tel: 0114 209 6206
Fax: 0114 209 6001

Suppliers of:

Powered Access Platforms
Aerial Work Platforms
Runabout Access Platforms
Scissor Lifts
Articulating Boom Access Platforms
Telescopic Boom Access Platforms
Material Lifts
Telehandlers
MEWPS Training