

## AH8 VM AH10 VM



- 10 ft 2 in (3,1m) outreach.
- Compact: 345°. Rotation with zero tail swing.
- 441 lb (200 kg) platform capacity.
- Proportional electric controls.
- High autonomy.
- Internal and external use

# AH8 VM & AH10 VM

## Advantages

- Full electric drive with the ability to drive at full height
- Proportional controls provide for smooth and progressive movements
- Narrow turning radius for better accessibility
- Increased safety with 3° slope sensor and pot hole protection
- The positive/negative jib offers more flexibility throughout the working envelope
- 2.8 mph (4.5 km/h) travel speed
- 23% gradeability
- Low total weight for easier transport and more applications
- Ergonomic and spacious cage design
- Robust, reliable and easy to maintain

## STANDARD FEATURES

- 24 V Electric motor
- 24 V – 240 Ah traction batteries
- 30 Amp battery charger
- Battery charge indicator
- 2 drive speed
- 2 back driving wheels
- 2 front steering wheels
- Non marking tyres
- Free wheel device
- Hourmeter
- Horn in cage
- Emergency stop buttons at cage and ground
- 2 Control stations, cage and ground

## OPTIONS & ACCESSORIES

- Centralised battery filling
- Flashing beacon
- Safety harness anchor points
- Motion alarm
- 220V line to cage
- Airline to cage

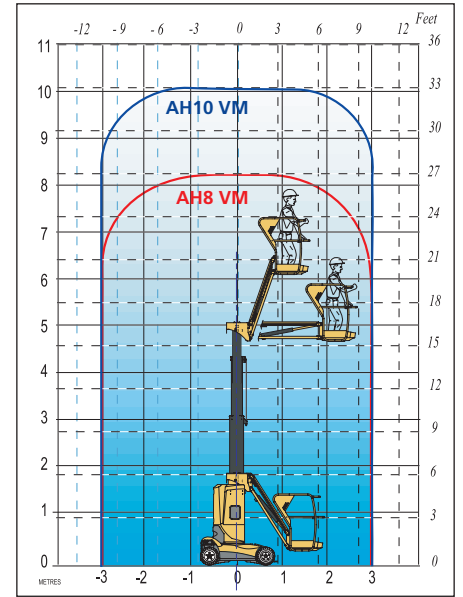
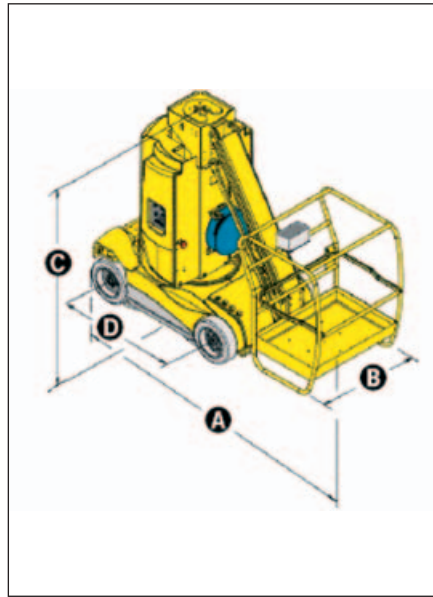

## SPECIFICATIONS

	AH8 VM	AH10 VM
Working Height	8.20 m / 28 ft 9 in	10 m / 32 ft 10 in
Platform Height	6.20 m / 22 ft 2 in	8 m / 26 ft 3 in
Horizontal outreach	3,1m / 10 ft 2 in	
Platform Capacity	200 kg / 441 lb	
<b>A</b> Length	2,65m / 8 ft 8 in	
<b>B</b> Width	0.99m / 3ft 2in	
<b>C</b> Stowed Height	1.99 m / 6 ft 6 in	
<b>D</b> Wheelbase	1.2 m / 3 ft 11 in	
Ground Clearance	de 2,5 cm à 10 cm / 1 in to 4 in	
Platform size	0.92x0.68m / 36 in x 27 in	
Tailswing	0	
Drive speed	0.7 - 4.5 km/h / 0.43 - 2.8 mph	
Outside turning radius	1.87m / 6ft 1 in	
Turntable rotation	345°	
Traction batteries	24 V (2 x 12 V) / 240 Ah	
Gradeability	23%	
Tilt alarm	3°	
Non marking tyres	16" x 5" x 10,5"	
Weight	2700kg / 5952 lb	2760 kg / 6085 lb

AS 1418.10



### Working At Height Limited

(Southern Office)  
Amberley Court  
Old Elstead Road  
Milford  
Surrey  
GU8 5EB

Tel: 01483 415 410  
Fax: 01483 417 719

### Working At Height Limited

(Northern Office)  
The Portergate  
Ecclesall Road  
Sheffield  
South Yorkshire  
S11 8NX

Tel: 0114 209 6206  
Fax: 0114 209 6001

### Suppliers of:

Powered Access Platforms  
Aerial Work Platforms  
Runabout Access Platforms  
Scissor Lifts  
Articulating Boom Access Platforms  
Telescopic Boom Access Platforms  
Material Lifts  
Telehandlers  
MEWPS Training